

Module 800-CON-RJ45

Transfer module for measurement device and module topologies - valid for basic devices of the 800 series

User manual and technical data

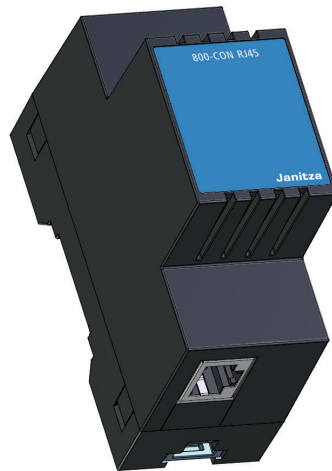
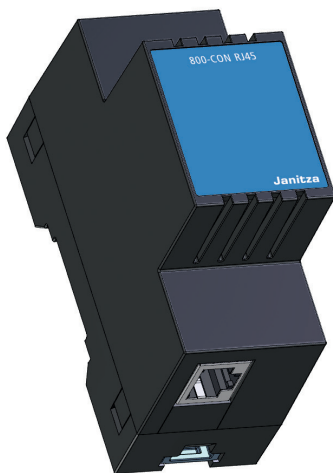

Suitable base devices and number of module slots:

Suitable base devices / Number of free slots	Slot assignment of an 800-CON-RJ45 module on the basic device
UMG 801 (from FW 1.7.3) / 12 slots + 1 slot for an additional 800-DI14 module	0 slots
UMG 800 (from FW 1.7.1) / 12 slots + 1 slot for an additional 800-DI14 module	0 slots
For more information on module slot combinations and JanBus system limits, refer to the respective user manual for the base unit.	

Tab. Suitable basic devices

Transfer module for measurement device and module topologies - (suitable for basic devices of the 800 series)

Doc. no.: 2.053.089.1.b

Date: 04/2026

The German version is the original edition of the documentation.

Subject to technical alterations.

The contents of our documentation have been compiled with great care and reflect the current state of the information available to us. Nonetheless, we wish to point out that updates of this document are not always possible at the same time as technical refinements are implemented in our products. Please see our website under www.janitza.com for the current version.

Please see our website under www.janitza.com for the current version.

Information about the GridVis software.

 Janipedia: wiki.janitza.de

 Tutorials: youtube.com/@gridvis

TABLE OF CONTENTS

1. Information on the devices and the user manual	6
1.1 Disclaimer.....	6
1.2 Copyright notice.....	6
1.3 Technical changes.....	6
1.4 About this user manual.....	6
1.5 Defective device/disposal.....	7
2. Safety	8
2.1 Display of warning notices and safety information.....	8
2.2 Hazard levels.....	8
2.3 Product safety.....	8
2.4 Hazards when handling the device, components and modules.....	9
2.5 Electrically qualified personnel.....	10
2.6 Warranty in the event of damage.....	10
2.7 Safety information for handling current transformers.....	10
3. Product description	12
3.1 800-CON-RJ45 transfer module.....	12
3.2 Incoming goods inspection.....	13
3.3 Intended use.....	13
3.4 Overview of module functions.....	13
3.5 EU conformity declaration.....	14
3.6 FCC Declaration of Conformity.....	14
3.7 Protective device/transformer.....	14
3.8 Scope of delivery.....	14
3.9 Accessories.....	14
3.10 Operating concept.....	15
3.11 GridVis Power Grid Monitoring Software.....	15
4. Mounting	16
4.1 Mounting the transfer module with output bus connector.....	16
4.2 Mounting the transfer module with input bus connector.....	18

5. Connections/controls	20
5.1 Designation and description	20
5.2 Module markings – rating plate.....	21
6. Installation	22
6.1 Trouble-free operation.....	22
6.2 Data transfer with 800-CON-RJ45 module.....	23
6.2.1 JanBus topology with 1-slot modules.....	24
6.2.2 Combined JanBus topology with 1-slot and 3-slot modules.....	25
6.2.3 JanBus topology with 3-slot modules.....	26
6.3 Data cable for connecting the 800-CON-RJ45 transfer modules.....	27
6.4 Configuration of measurement device and module topologies.....	27
7. Device views	28
8. Technical data	29
9. Dismounting/module exchange	30
10. Service and maintenance	32
10.1 Repair.....	32
10.2 Service.....	32
10.3 Device adjustment.....	32
10.4 Calibration interval.....	32
10.5 Firmware update.....	32
10.6 Procedure in the event of a malfunction.....	32
10.7 Resetting the module to the standard factory settings	32

1. Information on the devices and the user manual

1.1 Disclaimer

Compliance with the usage information for the devices, modules and components is a prerequisite for safe operation and attaining the stated performance characteristics and product features.

Janitza electronics GmbH assumes no liability for bodily injury, material damage or financial losses which result from disregard of the usage information.

Ensure that the usage information for the products is legible and accessible.

1.2 Copyright notice

© 2023 - Janitza electronics GmbH - Lahnau. All rights reserved.

Any reproduction, processing, distribution or other use of this usage information, in whole or in part, is prohibited.

All trademarks and the rights arising from them are the property of the respective owners of these rights.

1.3 Technical changes

- Make sure that your device (modules/components) matches the user manual.
- This user manual applies to the module 800-CON-RJ45. Separate validities and distinctions are marked.
- First make sure you have read and understood the usage information accompanying the product.
- Keep the usage information associated with the product available for the entire service life and pass it on to any possible subsequent users.
- Find out about device revisions and the associated modifications of the usage information associated with your product at www.janitza.com.

1.4 About this user manual

If you have questions, suggestions or ideas for improvement of the user manual, please let us know via email at: info@janitza.com.

INFORMATION

This user manual describes the 800-CON-RJ45 transfer module for JanBus communication in measurement device and module topologies with suitable basic devices (see „Tab. Suitable basic devices“ on p. 2) and provides information on operation.

Also consult the additional usage information relevant for this user manual, such as:

- the installation manual.
- the data sheet.
- the "Safety information" supplement.
- the supplement on mounting the modules.
- the usage information on the basic device and the integrated modules of your meter and module topology.

Moreover, the **GridVis** software has an “online help” feature.

INFORMATION

Our usage information uses the grammatical masculine form in a gender-neutral sense! This form always refers equally to women, men and diverse. In order to make the texts more readable, distinctions are not made. We ask for your understanding for these simplifications.

1.5 Defective device/disposal

Before sending **defective devices, modules or components** back to the manufacturer for testing:

- Contact the manufacturer's Support department.
- Send devices, modules or components complete with all accessories.
- When doing so, please bear the terms for transportation in mind.

INFORMATION

Please return defective or damaged devices, modules or components to Janitza electronics GmbH in accordance with the shipping instructions for air or road freight (complete with accessories).

Observe special regulations for devices with built-in batteries or rechargeable batteries!

Do not attempt to open or repair the device (the module, the component) on your own because otherwise all warranty claims become invalid!

For the **disposal** of the device (the module, the component), please observe national regulations! Dispose of individual parts, as applicable, depending on their composition and existing country-specific regulations, e.g. as

- Electronic waste,
- Batteries and rechargeable batteries,
- Plastics,
- Metals.

Engage a certified disposal company to handle scrapping as needed.

Information on "Service and maintenance" of your device can be found in chapter 10 on page 32.

2. Safety

The chapter on Safety contains information which must be observed to ensure your personal safety and avoid material damage.

2.1 Display of warning notices and safety information

The warning notices shown below

- are found throughout the usage information.
- can be found on the devices themselves.
- indicate potential risks and hazards,
- underscore aspects of the information provided that clarifies or simplifies procedures.



The additional symbol on the device, the module or the component itself indicates an electrical hazard that can lead to severe injury or death.



This general warning symbol draws attention to a possible risk of injury. Be certain to observe all of the information listed under this symbol in order to avoid possible injury or even death.



2.2 Hazard levels

Warning and safety information is marked by a warning symbol, and the hazard levels are shown as follows, depending on the degree of hazard:

⚠ DANGER
Warns of an imminent danger which, if not avoided, results in serious or fatal injury.

⚠ WARNING
Warns of a potentially hazardous situation which, if not avoided, could result in serious injury or death.

⚠ CAUTION
Warns of an immediately hazardous situation which, if not avoided, can result in minor or moderate injury.

ATTENTION
Warns of an immediately hazardous situation which, if not avoided, can result in material or environmental damage.

i INFORMATION

Indicates procedures in which there is **no** hazard of personal injury or material damage.

2.3 Product safety

The devices, components and modules reflect current engineering practice and accepted safety standards, but hazards can arise nonetheless.

Observe the safety regulations and warning notices. If notices are disregarded, this can lead to personal injury and/or damage to the product.

Every type of tampering with or use of the devices and the modules,

- which goes beyond the mechanical, electrical or other operating limits can lead to personal injury and/or damage to the product;
- constitutes “misuse” and/or “negligence” under the product’s warranty and thus voids the warranty for any possible resulting damage.

Read and understand the user manual and the usage information on the basic device before installing, operating, maintaining and using the devices, components and modules.

Only operate the devices, components and modules when they are in perfect condition and in compliance with this user manual and the usage information that is included. Send defective devices, components or modules back to the manufacturer in compliance with proper transport conditions.

Retain the user manual throughout the service life of your product and keep it at hand for consultation.

When using the device, component or module, also observe the legal and safety regulations for your system that are applicable for the respective use case.

2.4 Hazards when handling the device, components and modules

When operating electric devices, components or modules, it is unavoidable for certain parts of these devices to conduct hazardous voltage. Consequently, severe bodily injury or material damage can occur if they are not handled properly.

Therefore, when handling our devices, components, or modules, always observe the following:

- do not exceed the limit values specified in the user manual and on the rating plate! This must also be observed during testing and commissioning!
- Take note of the safety and warning notices in all usage information that belongs to the devices, modules or components!

WARNING

Disregarding the connection conditions of the Janitza measurement devices, modules or components can lead to injuries or even death or to material damage!

- Do not use Janitza meters, modules or components for critical switching, control or protection applications where the safety of persons and property depends on this function.
- Do not carry out switching operations with the Janitza measurement devices, modules or components without prior inspection by your system manager with specialist knowledge! In particular, the safety of persons, material assets and the applicable standards must be taken into account!

WARNING

Risk of injury due to electrical current and voltage!

Severe bodily injury or death can result! Therefore please abide by the following:

- **Do not touch bare, stripped wires or device inputs that are dangerous to touch on the devices, components and modules.**
- **Switch off your installation before commencing work! Secure it against being switched on! Check to be sure it is de-energized! Ground and short circuit! Cover or block off adjacent live parts!**
- **During operation and troubleshooting (especially with DIN rail devices), check the environment for dangerous voltages and switch these off if necessary!**
- **Wear protective clothing and protective equipment in accordance with applicable guidelines when working on electrical systems!**
- **Before making connections, ground the device / component / module by means of the ground wire connection, if present!**
- **Do not touching bare or stripped leads that are energized! Equip stranded conductors with wire ferrules!**
- **Hazardous voltages can be present in all circuitry parts that are connected to the power supply.**
- **Protect wires, cables and devices with a suitable line circuit breaker/fuse!**
- **Never switch off, remove or tamper with safety devices!**
- **There can still be hazardous voltages present in the device or in the component (module) even after it has been disconnected from the supply voltage (capacitor storage).**
- **Only connect screw terminals with the same number of poles and design!**
- **Do not exceed the limit values specified in the user manual and on the rating plate! This must also be observed during testing and commissioning.**
- **Take note of the safety and warning notices in the usage information that belongs to the device, components or modules!**

2.5 Electrically qualified personnel

To avoid bodily injury and material damage, only electrically qualified personnel are permitted to work on the devices and their components, modules, assemblies, systems and current circuits who have knowledge of:

- The national and international accident prevention regulations.
- Safety technology standards.
- Installation, commissioning, operation, disconnection, grounding and marking of electrical equipment.
- the requirements concerning personal protective equipment.

Electrically qualified persons within the scope of the technical safety information of all usage information associated with the device and its components (modules) are persons who can furnish proof of qualification as an electrically skilled person.

WARNING

Warning against unauthorized manipulation or improper use of the device or its components (modules)!

Opening, dismantling or unauthorized manipulation of the device and its components (modules) which goes beyond the mechanical, electrical or other operating limits indicated can lead to material damage or injury, up to and including death.

- **Only electrically qualified personnel are permitted to work on the devices and their components (modules), assemblies, systems and current circuits.**
- **Always use your devices or components (modules) only in the manner described in the associated documentation.**
- **If there is discernible damage, send the device or the component (module) back to the manufacturer!**

2.6 Warranty in the event of damage

Any unauthorized tampering with or use of the device, component or module constitutes "misuse" and/or "negligence" under the product's warranty and thus voids the warranty for any possible resulting damage. Note in this regard Sect. "3.3 Intended use" on p. 13.

2.7 Safety information for handling current transformers

The field of transformer technology groups the totality of all devices that perform the function of a current, voltage or measuring transformer together as sensors.

The usage information for our devices, modules and components contains the terms **current transformer, voltage transformer or transformer**, which are representative for **sensors**.

A further distinction is drawn between the terms **current transformer (CT)** and **low-power current transformer (LP-CT)** :

The term "current transformer" is used for special transformers for the primary-proportional conversion of currents of large magnitudes to directly measurable, smaller current values.

In contrast, the term "LP current transformer" (low-power current transformer) is used for special transformers for the primary-proportional conversion of currents of large magnitudes to directly measurable, smaller voltage values (low power).

Current transformers and LP current transformers provide safe galvanic isolation between the primary circuit and the measurement circuit due to their design and their physical operating principle. For Janitza measurement devices, modules and components, use only "**transformers for measuring purposes**" which are suitable for the energy monitoring of your system! Observe the corresponding warning notices!

Basic devices use only the term "**current transformer**" in the display for the configuration of both **current transformers** and **LP current transformers**.

⚠ WARNING**Risk of injury or damage to the meter due to high measured currents/measured voltages at the connections of the current transformers!**

High measurement currents can cause temperatures of up to 80 °C (176 °F) on the connections of the current transformers

- **Use wiring that is designed for an operating temperature of at least 80 °C (176 °F)!**
- **Only use current transformers with basic insulation to IEC 61010-1:2010!**
- **Make sure that screw terminals for the current transformer connection on the device are adequately tightened!**
- **Comply with the information and provisions in the documentation of your current transformers!**
- **Ground connections present on the secondary windings of the current transformers must be connected to ground!**
- **The current transformers can be hot even after the power supply has been switched off. Allow the connections of the current transformers and the connecting cables to cool down before touching them!**

⚠ CAUTION**Risk of injury or damage to the basic device (module) and/or your system due to a short circuit!**

Inadequate insulation at the current measurement inputs of the modules with respect to the supply circuits of the basic device can cause dangerous voltages at the measurement input or damage to your device (module)/system.

- **Ensure reinforced or double insulation with respect to the supply circuits!**

3. Product description

3.1 800-CON-RJ45 transfer module

The 800-CON-RJ45 transfer module transmits the JanBus communication of a suitable basic device (see „Tab. Suitable basic devices“ on p. 2) via an RJ45 cable (RJ45 patch cable) to remote measurement points.

The transfer module allows the implementation of measurement device and module topologies using a flexible arrangement of DIN rails (see Sect. “8. Technical data” on p. 29 for suitable types) in switch-board cabinets or small distribution boards.

The JanBus interface of the 800-CON-RJ45 transfer module is a proprietary RJ45 JanBus interface! Do not connect to RJ45 Ethernet interfaces!

i INFORMATION

When setting up your meter and module topology, note the following:

- The scope of delivery for the 800-CON-RJ45 transfer module includes **one input and one output bus connector each**, so that each transfer module can be used with the corresponding bus connector at the output or input of a measurement device and module series.
- The maximum bus length (JanBus - proprietary) for setting up measurement device and module topologies can be found in Sect. “8. Technical data” on p. 29.
- In addition to the usage information for the 800-CON-RJ45 module, also observe all usage information for the modules and components integrated in the JanBus topology, especially that of your basic device!



Fig.: Transfer module
800-CON-RJ45 - top view

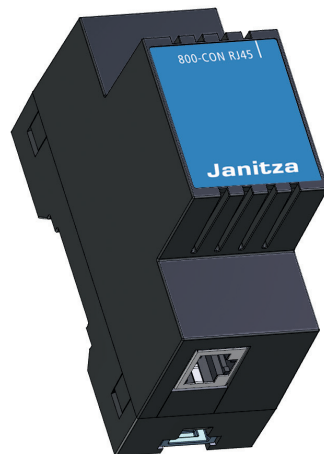

Fig.: Transfer module
800-CON-RJ45 - 3D view
with proprietary RJ45 JanBus
interface

3.2 Incoming goods inspection

The prerequisites for trouble-free and safe operation of the module include proper transport, storage, setup and assembly, as well as proper operation and maintenance.

Exercise due caution when unpacking and packing the device, do not use force and only use suitable tools.

Check the following:

- the module by performing a visual inspection to ensure flawless mechanical condition.
- the scope of delivery (see Sect. "3.8 Scope of delivery" on p. 14) for completeness before beginning with assembly and installation.

If it must be assumed that safe operation of your basic device with module is not possible:

1. **Switch off the power to your system (your device)!**
2. **Secure it against being switched back on!**
3. **Check to be sure it is de-energized!**
4. **Ground and short circuit the system (device)!**
5. **Cover or block off adjacent live parts!**

Safe operation is impossible, if, for example, the basic device with module:

- Has visible damage,
- No longer functions despite an intact power supply,
- Was subjected to extended periods of unfavorable conditions (e.g. storage outside of the permissible climate thresholds without adjustment to the room climate, condensation, etc.) or transport stress (e.g. falling from an elevated position, even without visible external damage, etc.).

ATTENTION

Improper handling may cause damage to the module and result in material damage!

The contacts of the bus connectors (JanBus interface) can bend or break off and destroy the bus connector.

- **Never touch or manipulate the contacts of the bus connector!**
- **Never force the bus connector into the module! Please note Sect. "4. Mounting" on p. 16 in this regard.**
- **When handling, transporting and storing the module, protect the contacts of the bus connector!**

3.3 Intended use

The module / component

- is only for use in the industrial sector.
- is intended as an expansion or transfer module for a measurement device and module topology with suitable basic devices (see „Tab. Suitable basic devices“ on p. 2) in switchboard cabinets and small distribution boards.
- must only be mounted with a basic device that is disconnected from the power supply (see Sect. "4. Mounting" on p. 16).

The basic device and the modules are **not** designed for installation:

- In vehicles! Use of the basic device with modules in non-stationary equipment is considered an exceptional environmental condition and is only permissible by special agreement.
- In environments with harmful oils, acids, gases, vapors, dusts, radiation, etc.
- In potentially explosive environments.

3.4 Overview of module functions

- JanBus interface module (proprietary) for communication between suitable basic devices (see „Tab. Suitable basic devices“ on p. 2) via an RJ45 cable (patch cable) in a module topology.
- The maximum bus length (JanBus - proprietary) for setting up measurement device and module topologies can be found in Sect. "8. Technical data" on p. 29.

3.5 EU conformity declaration

Please see the EU/UKCA declarations of conformity posted at www.janitza.com for the laws, standards and directives applied by Janitza electronics GmbH for the devices. The EU/UKCA conformity of the device permits the marking CE/UKCA.

3.6 FCC Declaration of Conformity



The device

- complies with Part 15 of the FCC Rules for Class B digital devices (limits to protect against harmful interference in a residential installation).
- generates, uses and can radiate high-frequency energy
- can cause harmful interference to radio communications if not installed and used properly. There is no guarantee that interference will not occur in a particular installation.

If there is radio or television reception interference, which can be determined by turning the device on and off, proceed as follows:

- Align or reposition the receiving antenna.
- Increase the distance between the device and the radio/television receiver.
- Connect the device and the radio/television receiver in different circuits.
- if necessary, contact Janitza support or a radio/television technician.

Code of Federal Regulations, Title 47, Part 15, Subpart B - Unintentional Radiators.

3.7 Protective device/transformer

It is not permitted to use the outputs of Janitza measurement devices, components and modules for switching protective devices or protective relays! Use only "Current transformers for measuring purposes" for Janitza measurement devices, components and modules!

3.8 Scope of delivery

Quantity	Part. no.	Designation
1	5231242	Module 800-CON-RJ45 - 2HP (horizontal pitches) transfer module
1	5231243	Bus connector - transfer on left (output bus connector)
1	5231244	Bus connector - transfer on right (input bus connector)
2	1001953	End bracket
1	3303888	Installation manual (DE/EN)
1	3303342	"Safety information" supplement (12 languages)

Tab. Scope of delivery, 800-CON-RJ45 transfer module

i INFORMATION

- The modules are delivered with the necessary screw terminals and bus connectors (JanBus interface) for connection to the basic device or other modules.
- All supplied options and design variants are described on the delivery note.
- The GridVis Power Grid Monitoring Software is available at www.janitza.com and can be used to configure your basic device with modules and read out data for analysis (prerequisite: PC connection to your basic device).

3.9 Accessories

Quantity	Part. no.	Designation
1	5231213	800-CT24 current measuring module
1	5231230	800-CT8-A current measuring module
1	5231234	800-CT8-LP current measuring module
1	5231214	800-DI14 digital input module

Tab. Available accessories for 800-CON-RJ45 transfer module

3.10 Operating concept

As described in section "3.1 Module 800-CON-RJ45" on page 14, the UMG 800-CON-RJ45 expansion and transfer module is used to connect remote measurement points.

The modules can be used to realize meter and module topologies with a flexible arrangement of the DIN rails. For the operation of the devices, components and modules integrated in your meter and module topology, please refer to the respective additional usage information.

INFORMATION

This user manual describes modules and provides information on operating the modules via a basic device.

Please refer to the user manual for the basic device (see „Tab. Suitable basic devices“ on p. 2) for operating, configuring and reading out additional modules.

The GridVis software has an online help with tutorials.

A list of parameters and Modbus addresses with data on your basic device with module is available for you as a download at www.janitza.com.

3.11 GridVis Power Grid Monitoring Software

The GridVis software provides you with the perfect tool for programming, reading, visualizing and analyzing measurement data (prerequisite: PC connection with your basic device)

You can download the GridVis software at www.janitza.com.

Performance characteristics of the GridVis software

- Configuration of the basic device and the modules of your meter and module topology.
- Graphic display of measured values.
- Online help and tutorials.

Connections to the PC (GridVis software)

Information on connections for communication between the PC and the basic device (with modules) can be found in the usage information of the basic device.

4. Mounting

⚠ CAUTION

Disregard of the installation instructions may cause property damage or personal injury!

Disregard of the installation instructions may cause damage to your basic device with module or destroy it and/or may also result in personal injury.

- **In addition to the installation instructions for your module, also observe the installation instructions for your basic device, in particular the safety and warning information.**
- **Before installing modules**
 - **Disconnect the supply of power to the system!**
 - **Secure it against being switched on!**
 - **Check to be sure it is de-energized!**
 - **Ground and short circuit!**
 - **Cover or block off adjacent live parts!**
- **Operate the basic device that belongs to the 800-CON-RJ45 module only with a supply voltage of 24 V! Observe the technical specifications in the usage information for the basic device.**
- **Provide adequate air circulation in your installation environment and cooling, as needed, when the ambient temperatures are high.**
- **Return defective modules to Janitza electronics GmbH in accordance with the shipping instructions for air or road freight (complete with accessories).**
- **All usage information is available for download at www.janitza.com.**

ⓘ INFORMATION

- The following module assembly sequence must be observed!
- Always mount the components of your JanBus system starting from the output bus connector to the input bus connector. This will avoid an incorrect connection of remote JanBus systems! Cf. Sect. "6.2 Data transfer with 800-CON-RJ45 module" on p. 23.
- Allow for sufficient space in your installation environment and for the bending radius of the RJ45 cables.
- Use end brackets to set up your meter and module topology on a suitable DIN rail (for DIN rail types, see Sect. "8. Technical data" on p. 29).

Please note before installing the module:

The scope of delivery of the 800-CON-RJ45 transfer module includes **one input and one output bus connector each**, so that each transfer module can be used with the corresponding bus connector at the output or input of a measurement-device and module series (see the step "Device description and example topologies").

Output bus connector 2HP (horizontal pitches)

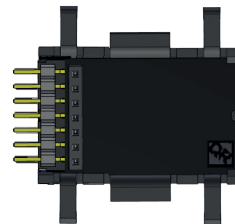

Fig.: Output bus connector for the 800-CON-RJ45 transfer module at the output of a series of measurement devices and modules.

Input bus connector 2HP (horizontal pitches)



Fig.: Input bus connector for the 800-CON-RJ45 transfer module at the input of a series of measurement devices and modules.

4.1 Mounting the transfer module with output bus connector

While observing the mounting instructions for your basic device or the connected module (e.g. check the bus connector mounting!), mount the 800-CON-RJ45 transfer module with output bus connector when the system is disconnected from the power supply as follows:

ATTENTION

Improper handling may cause damage to the module and result in material damage!

The contacts of the bus connectors (JanBus interface) can bend or break off and destroy the bus connector.

- **Never touch or manipulate the contacts of the bus connector!**
- **Never force the bus connector into the module!**
- **When handling, transporting and storing the module, protect the contacts of the bus connector!**

1. Press in the bottom bolts on the rear of the module.
2. If this has not yet been done, press the bus connector (JanBus interface) included in the respective scope of delivery into the sockets on the rear of your module.

Bottom bolt, pressed in

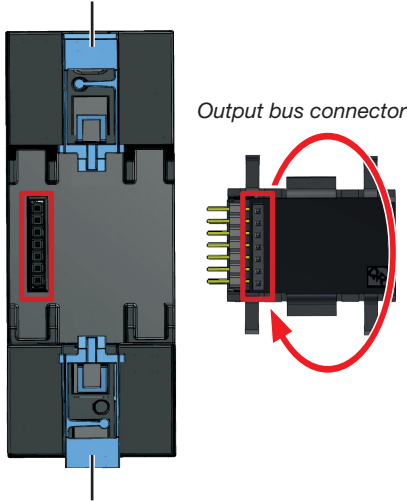

Bottom bolt, open

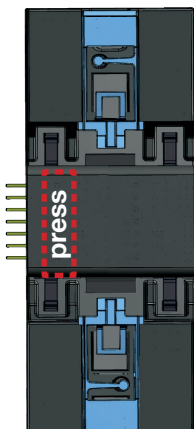
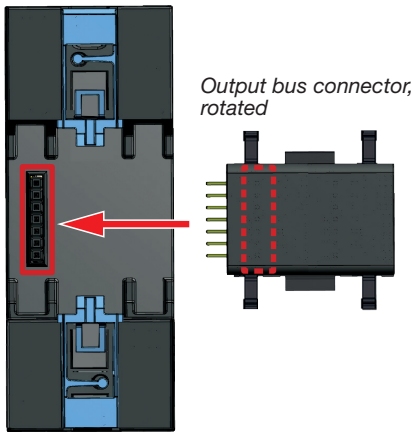

Figures:
Module rear views

3. Press the **transfer module with output bus connector** onto the DIN rail until the bottom bolts audibly engage.

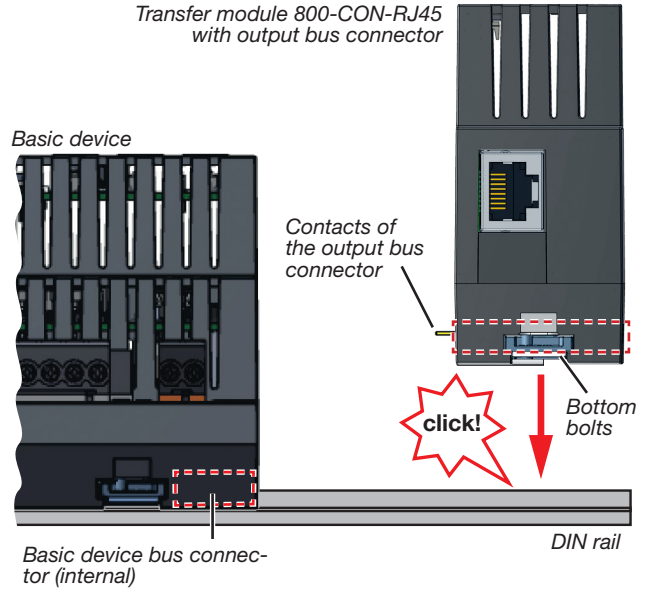

ATTENTION

Material damage due to voltage applied to the basic device during installation!
Coupling while energized can destroy your basic device or the module!

- **Observe the warnings and safety information at the beginning of this chapter and check to be certain your basic device is de-energized before connecting modules!**

4. Push the contacts of the transfer module with output bus connector into the **sockets of the basic device bus connector or into the sockets of the connected module** so that the devices are coupled.

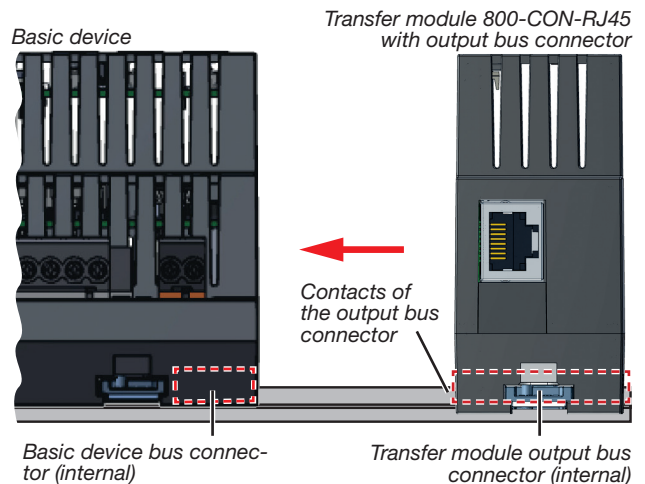

5. Check the fit of your measurement-device and module series and mount end brackets.

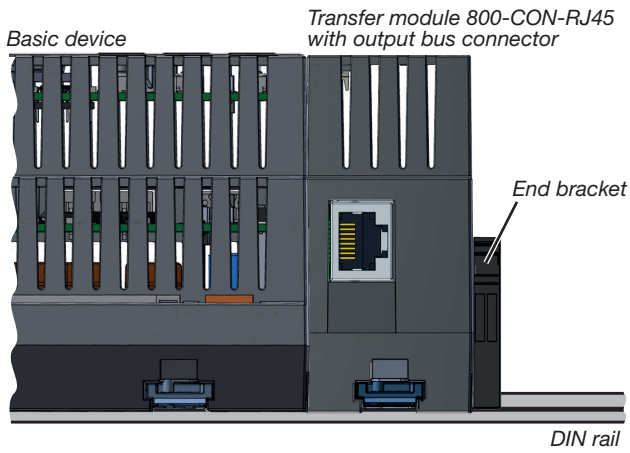

i INFORMATION

Always install the **800-CON-RJ45 transfer module with output bus connector** at the end of your measurement device and module topology (see Sect. "6. Installation" on p. 22).

4.2 Mounting the transfer module with input bus connector

For spatially distant module series, mount the **800-CON-RJ45 transfer module with input bus connector** while the system is disconnected from the power supply:

1. Press in the open bottom bolts on the rear of the transfer module.
2. If not already done, press the supplied input bus connector (JanBus interface) into the sockets on the back of the transfer module.

Bottom bolt, pressed in

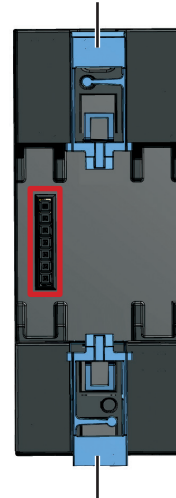

Input bus connector

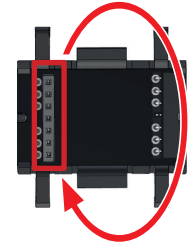

Bottom bolt, open

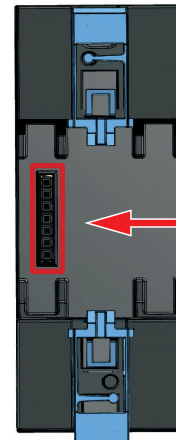

Input bus connector, rotated

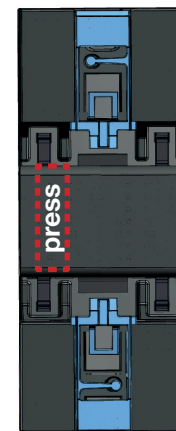
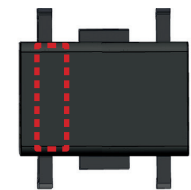

- Press the transfer module with input bus connector onto the DIN rail until the bottom bolts audibly engage.

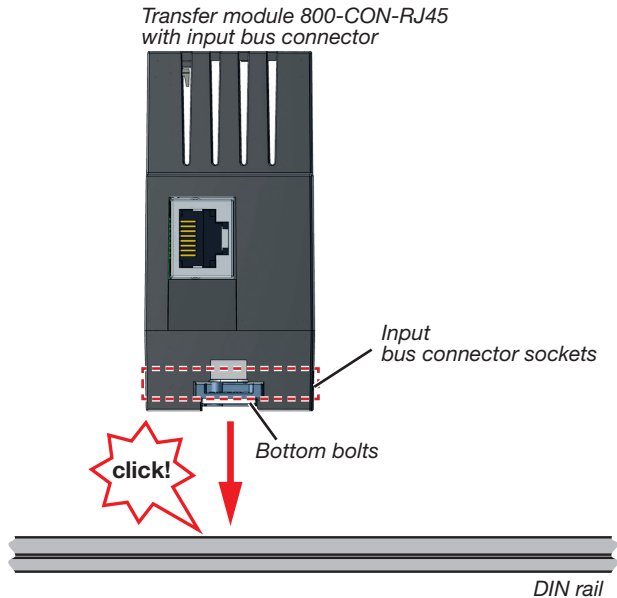

- Mount further modules (e.g. current measuring modules, digital input modules) and push their contacts into the sockets of the input bus connector so that the devices are coupled to the transfer module.
- Check the fit of your device and module series and mount end brackets.

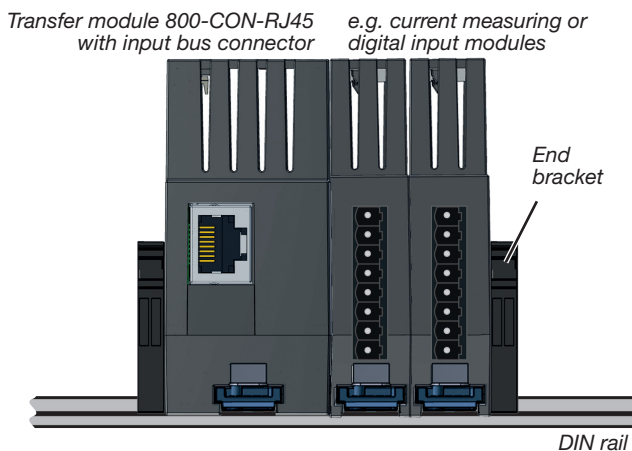

- Finally, wire your series of measurement devices and modules, observing the usage information of all integrated devices and modules.
- Apply voltage to the basic device (system). The basic device detects the modules automatically.

ⓘ INFORMATION

- Always install the **800-CON-RJ45 transfer module with input bus connector** at the beginning of your remote measurement point (for further module series see Sect. "6. Installation" on p. 22).
- In addition to the usage information of the basic device and the 800-CON-RJ45 transfer module, please also note any other usage information of the modules and components integrated in your JanBus topology.
- For recommended data cables, refer to Sect. "6.3 Data cable for connecting the 800-CON-RJ45 transfer modules" on p. 27.
- The maximum bus length (JanBus - proprietary) for setting up measurement device and module topologies can be found in Sect. "8. Technical data" on p. 29.
- Use end brackets to set up your measurement device and module series on the DIN rails.

5. Connections/controls

5.1 Designation and description

i INFORMATION

The scope of delivery of the 800-CON-RJ45 transfer module includes one input and one output bus connector each, so that each transfer module can be used with the corresponding bus connector at the output or input of a measurement device and module series (see Sect. "4. Mounting" on p. 16 and Sect. "6. Installation" on p. 22).

i INFORMATION

Suitable modules for a JanBus meter and module topology can be found in Sect. "3.9 Accessories" on p. 14.

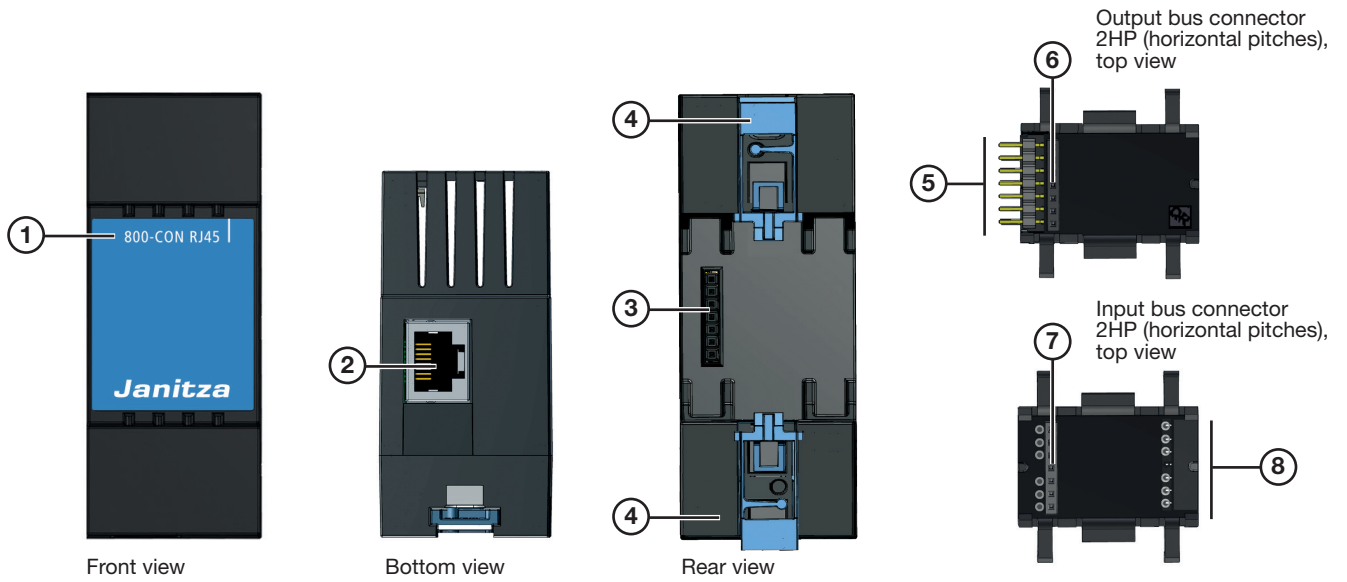

Item	Designation	Description
1	Module name	Module designation
2	JanBus interface (Out)	RJ45 interface via RJ45 cable (RJ45 patch cable) for forwarding JanBus communication to remote measurement points.
3	JanBus interface (In)	Connection contacts for the output bus connector (item 6) or input bus connector (item 7).
4	Bottom bolts	For mounting the module on the DIN rail.
5	Output bus connector (JanBus interface)	Contacts for insertion into the basic device or an attached module.
6	Output bus connector (JanBus interface)	Sockets for the connection contacts on the back of the module (item 3).
7	Input bus connector (JanBus interface)	Sockets for the connection contacts on the back of the module (item 3).
8	Input bus connector (JanBus interface)	Sockets for inserting bus connector contacts of other modules.

5.2 Module markings – rating plate



Item	Designation	Description
1	Part number	Marking for traceability.
2	Symbol for “Danger sign”	General hazard symbol. Be certain to observe the warning notices applied to the device and shown in the documentation in order to avoid possible injury or even death.
3	Device description (identification)	Device designation (model, device type).
4	DataMatrix code	Coded manufacturer data.
5	Manufacturer	Full contact address of the manufacturer (Company name, street, house number, postal code, city, country).
6	CE conformity marking	See section „3.5 EU conformity declaration“ on p. 14.
7	Manufacturer-specific data	Manufacturer data.
8	Hardware version	Hardware version of the module.
9	Type/serial number	Number for identification of the device.
10	Designation of origin/web address	Country of origin and manufacturer’s web address

6. Installation

⚠ WARNING

Risk of injury due to high currents and high electrical voltages!

Severe bodily injury or death can result from:

- Touching bare or stripped leads that are energized.
- Inputs of devices, components and modules are dangerous to touch.

Therefore, please note for your system:

- **Disconnect the supply of power before starting work!**
- **Secure it against being switched on!**
- **Check to be sure it is de-energized!**
- **Ground and short circuit! Use the ground connection points with the ground symbol for grounding!**
- **Cover or block off adjacent live parts!**

ℹ INFORMATION

The **800-CON-RJ45** transfer module with output bus connector on the basic device or on modules connected in series

- **is always located at the end of a series of measurement devices and modules.**
- **cannot forward any JanBus communication via the output bus connector!**

6.1 Trouble-free operation

For trouble-free operation of the devices and thus of the system, connect the transfer modules for JanBus communication with RJ45 cables (RJ45 patch cables - not included in delivery!). When mounting, make sure to provide sufficient space in your installation environment and to observe the bending radius of the RJ45 cables!

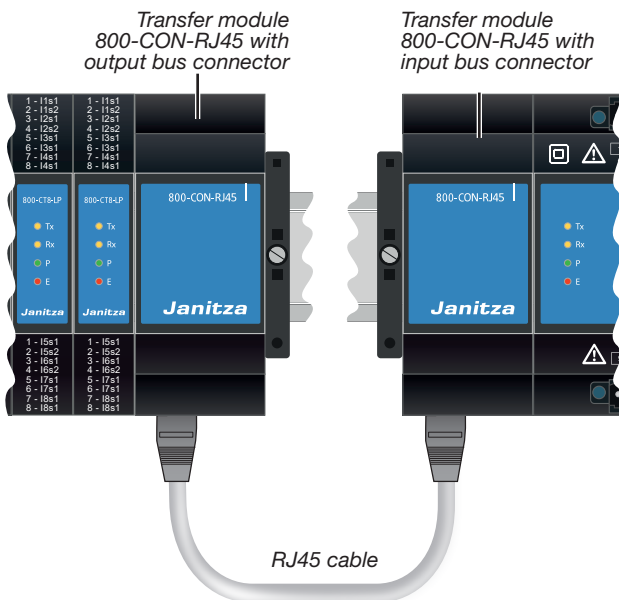
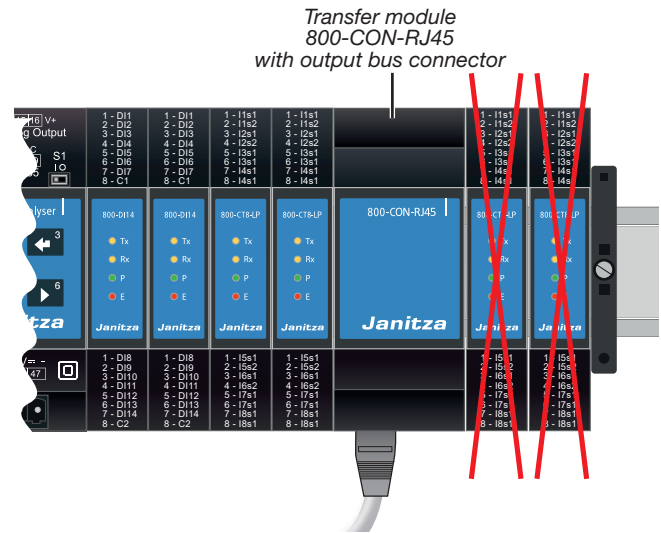

Fig. Example of measurement-device and module topology; RJ45 cabling of the transfer modules with output and input bus connectors.

Fig. Example of measurement-device and module topology; No forwarding of JanBus communication by transfer modules with output bus connectors.

6.2 Data transfer with 800-CON-RJ45 module

Check the maximum number of slots on your basic device (see „Tab. Suitable basic devices“ on p. 2). To use all available slots of a basic device, the following JanBus measurement device and module topologies, for example, can be realized using the 800-CON-RJ45 transfer module:

1. A **JanBus topology** consisting of 1-slot modules until the maximum number of slots of the basic device is exhausted (e.g. digital input module 800-DI14, current measuring module 800-CT8-A, current measuring module 800-CT8-LP).
2. A **combined JanBus topology** consisting of 1-slot and X-slot modules until the maximum number of slots of the basic device is exhausted (e.g. a combination of 1-slot and 3-slot modules, such as the 800-CT24).
3. One **JanBus topology 800-CT24**, for example, consisting of several 3-slot modules until the maximum number of slots of the basic device is exhausted (e.g. a JanBus topology with 3 current measuring modules of the type 800-CT24, which together occupy 9 slots).

i INFORMATION

System limits:

- The maximum bus length (JanBus - proprietary) for setting up measurement device and module topologies can be found in Sect. "8. Technical data" on p. 29.
 - Use a commercially available RJ45 cable (RJ45 patch cable) for trouble-free JanBus communication in your measurement-device and module topology.
 - The 3 following measurement-device and module topologies with JanBus communication are examples! **Before mounting, please check the number of suitable modules for your measurement-device and module topology based on the respective usage information.**
 - **Do not exceed the maximum number of module slots of the basic device (the 800-CON-RJ45 transfer module does not occupy a slot)!**
 - The scope of delivery of the 800-CON-RJ45 module can be found in the user manual for the module.
-

6.2.1 JanBus topology with 1-slot modules

Example of a JanBus topology with 10 modules that each occupy one module slot on the basic device (2x digital input modules 800-DI14, 2x current measuring modules 800-CT8-LP and 6x current measuring modules 800-CT8-A) and 4 transfer modules (that do not occupy a module slot).

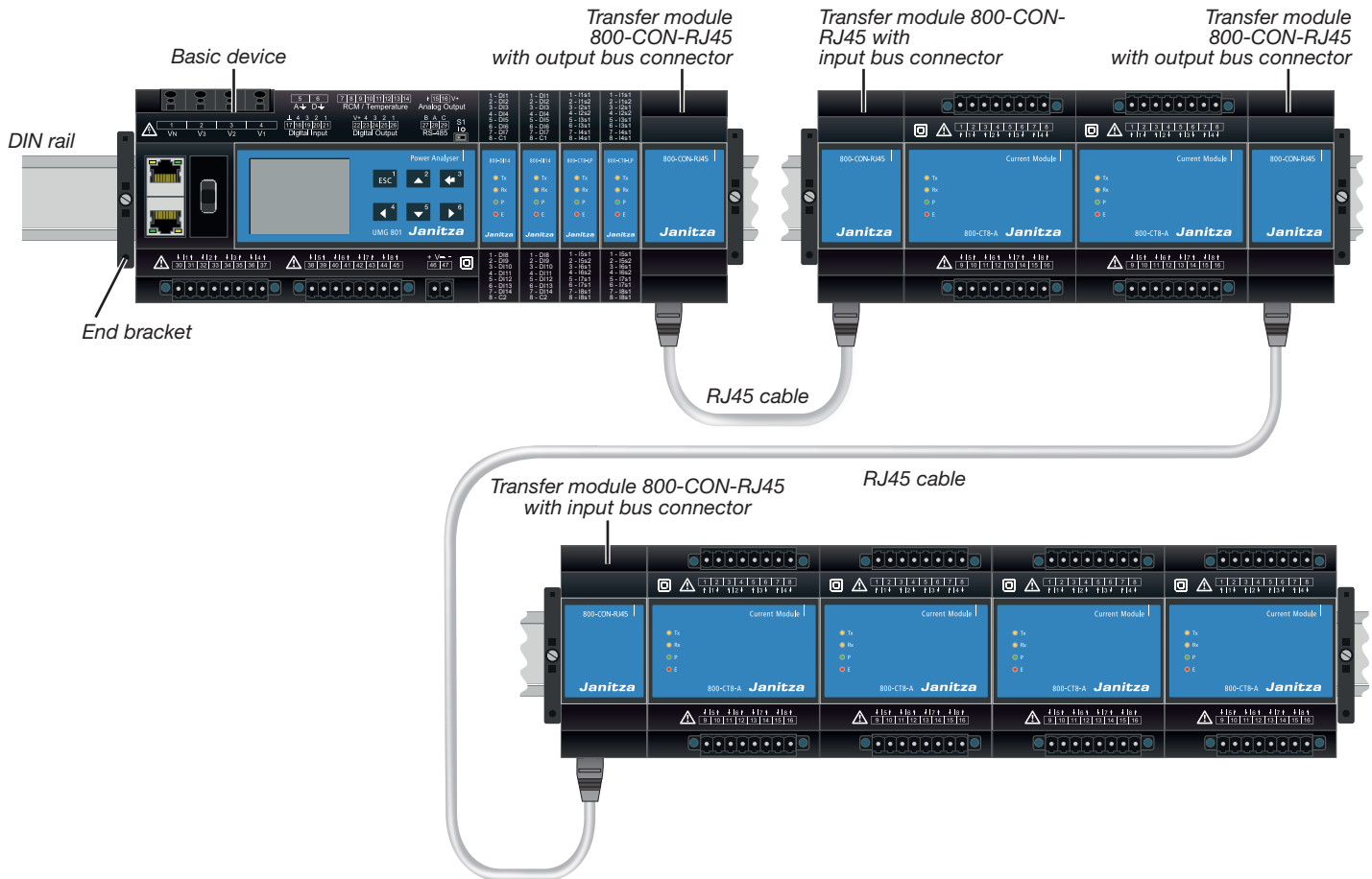

Fig. example: Measurement device and module series with 10x 1-slot modules distributed over 3 measurement points.

6.2.2 Combined JanBus topology with 1-slot and 3-slot modules

Example of a combined JanBus topology with five 800-DI14 digital input modules (that occupy 5 module slots on the basic device), one 800-CT24 current measuring module (that occupies 3 module slots) and two 800-CT8-LP current measuring modules (that occupy 2 module slots).

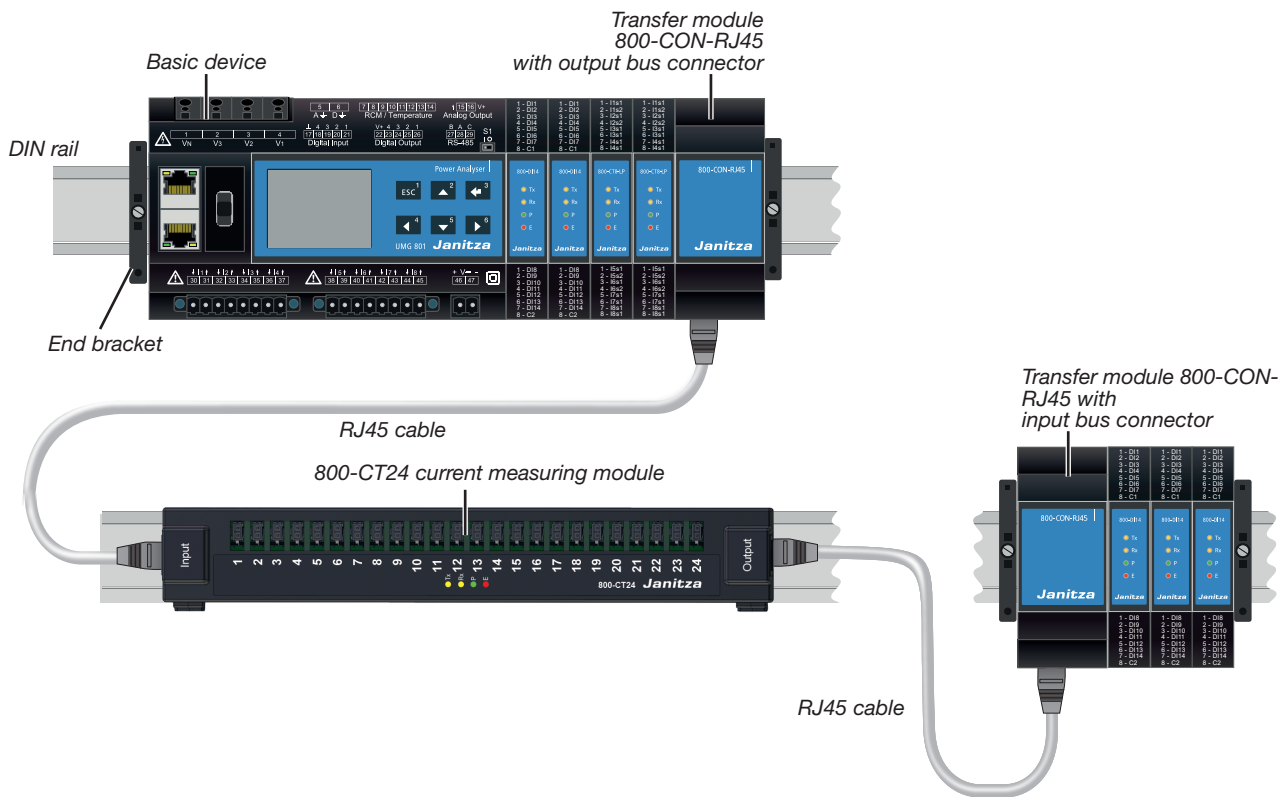

Fig. example: Measurement device and module series with 7x 1-slot modules and 1x 3-slot module distributed over 3 measurement points.

6.2.3 JanBus topology with 3-slot modules

Example of a JanBus topology with three 800-CT24 current measuring modules (each occupying 3 module slots of the basic device).

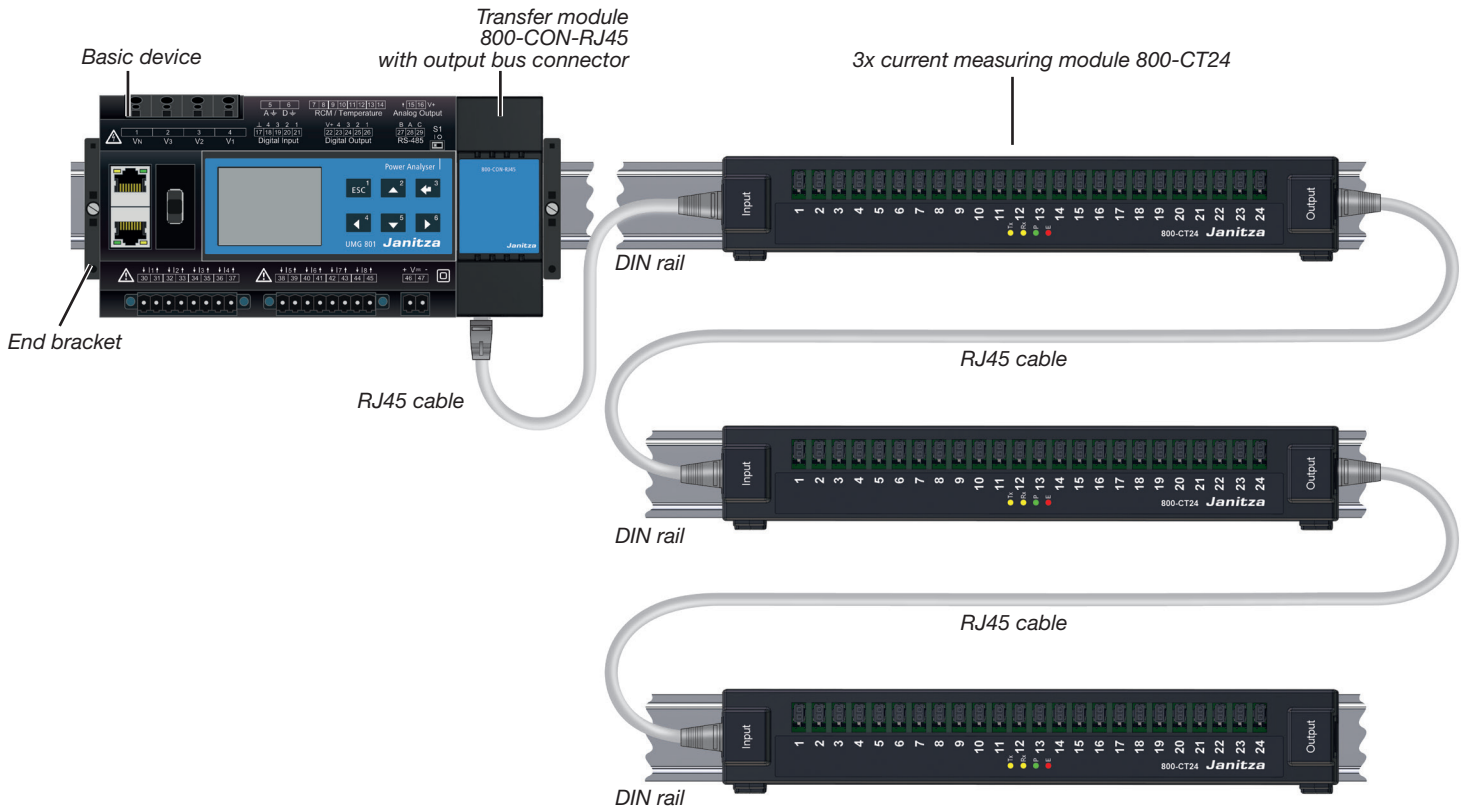

Fig. example: Measurement device and module series with 3x 3-slot modules distributed over 4 measurement points.

6.3 Data cable for connecting the 800-CON-RJ45 transfer modules

Use RJ45 patch cables for trouble-free JanBus communication in measurement device and module topologies via the RJ45 JanBus interfaces of the modules. **Please also refer to the usage information for the basic device and the modules.**

ATTENTION

Material damage due to confusion with the Ethernet interfaces!

The JanBus interface of the 800-CON-RJ45 module is a proprietary RJ45 JanBus interface! Any connection to an RJ45 Ethernet interface may interfere with devices and modules in your JanBus topology or cause your network to fail!

- **Use the JanBus interface of the 800-CON-RJ45 module exclusively in proprietary RJ45 JanBus topologies!**
- **Check with your network administrator for the correct setup of your measurement-device and module topology.**

The maximum bus length (cable lengths of the RJ45 cables) of the JanBus (proprietary) can be found in Sect. "8. Technical data" on p. 29.

6.4 Configuration of measurement device and module topologies

The installation, commissioning and configuration of your measurement device and module topology is carried out without a PC via the basic device.

i INFORMATION

- For details and information on the display and button functions of the basic device, refer to the usage information of the basic device.
- The **GridVis** Power Grid Monitoring Software is available at www.janitza.com and can be used to configure your basic device with modules and read out data for analysis (prerequisite: **PC connection to your basic device**).

ATTENTION

The basic device in a topology with transfer modules does not recognize modules during the power-up procedure If there is no communication to modules, the module functions are not supported (e.g. current measurements).

- **Switch off the power supply to your system.**
- **Check the installation of the basic device with transfer module and the connection (JanBus interface/RJ45 cable) to your modules:**
 - **Check the contacts and seating of the transfer module on the bus connector.**
 - **Check the fit of the RJ45 cables, if necessary rewire the connected modules (use commercially available RJ45 patch cables).**
 - **Do not exceed the maximum length of the JanBus. Observe the information on this in Sect. "8. Technical data" on p. 29.**
- **If necessary, restart the basic device.**
- **If these measures do not lead to the desired result, please contact our Support – www.janitza.com.**

7. Device views

- The figures are for illustration purposes only and are not to scale.
- Dimensions in mm (in).

Front view

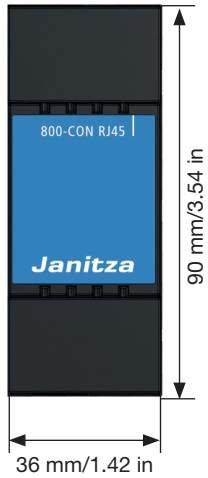

View from left

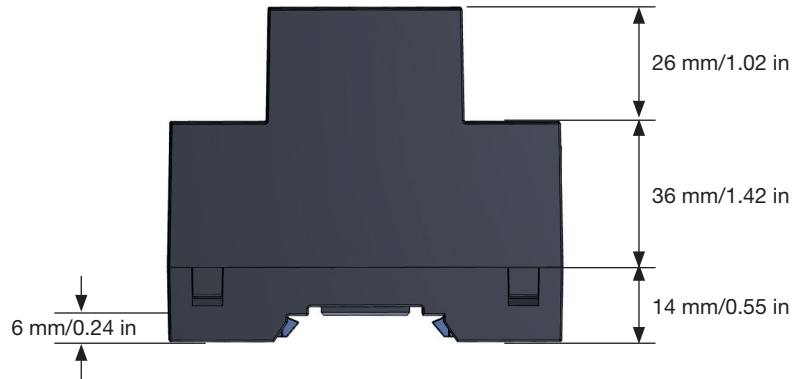

Bottom view

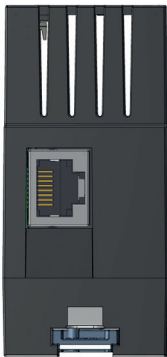

Top view



Rear view

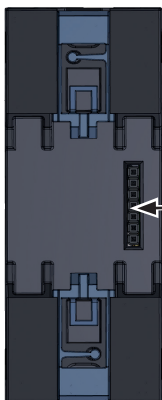

Bus connector (JanBus interface)

Output bus connector 2HP

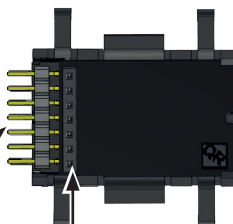

Input bus connector 2HP

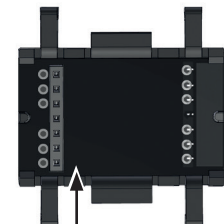

Connection contacts for the bus connector sockets

Contacts of the output bus connector for insertion into the basic device or connected modules

Bus connector sockets for insertion into the transfer module

Bus connector sockets for insertion into the transfer module

Sockets of the input bus connector for connected modules

8. Technical data

General	
Net weight	approx. 62 g (0.14 lbs)
Device dimensions	Approx. W = 36 mm (1.42 in), H = 90 mm (3.54 in), D = 76 mm (2.99 in)
Width of the device in horizontal pitches (HP)	2HP (1HP = 18 mm)
Mounting orientation	As desired
Fastening/mounting - Suitable DIN rails - (35 mm / 1.38 in)	TS 35/7.5 according to EN 60715 TS 35/10 TS 35/15 x 1.5
Protection against foreign matter and water	IP20 according to EN60529
Impact resistance	IK07 according to IEC 62262

Transport and storage	
The following information applies to devices, modules and components transported and stored in their original packaging.	
Free fall	1 m (39.37 in)
Temperature	K55: -25° C (-13 °F) to +70° C (158 °F)
Relative humidity	0 to 95% at 25 °C (77 °F), no condensation

Environmental conditions during operation	
The device · Is for weather-protected and stationary use. · Fulfills operating conditions according to DIN IEC 60721-3-3. · Has protection class II according to IEC 60536 (VDE 0106, part 1), a ground wire connection is not required!	
Rated temperature range	-10 °C (14 °F) to +55 °C (131 °F)
Relative humidity	5 to 95% at 25 °C (77 °F), no condensation
Pollution degree	2
Ventilation	No forced ventilation required.

Interfaces	
JanBus interface (In) - (proprietary Ethernet)	RJ45 - JanBus interface via bus connector
JanBus interface (Out) - (proprietary Ethernet)	RJ45 - JanBus via RJ45 cable (RJ45 patch cable)
JanBus (proprietary) - Max. bus lengths/cable lengths of the RJ45 cables	Cat 7/7a = 100 m (AWG 22: Ø = 0.64 mm, cross-sectional area = 0.33 mm ²)
	Cat 6/6a = 75 m (AWG 23: Ø = 0.57 mm, cross-sectional area = 0.26 mm ²)
	Cat 5/5e = 60 m (AWG 24: Ø = 0.51 mm, cross-sectional area = 0.21 mm ²)

INFORMATION

Detailed information on the functions and data of the basic device can be found in the usage information included with the basic device or available for download at www.janitza.com!
Please also note the usage information for the modules integrated in your measurement device and module topology! You can also find all usage information as a download at www.janitza.com.

9. Dismounting/module exchange

ATTENTION

Handling your module too roughly may cause damage to the module and result in material damage!

The bus connector contacts and the bottom bolts can be damaged or broken off when dismantling your module.

- Never pull the module out of the DIN rail forcefully.
- First decouple the bus connectors (JanBus interface) and carefully unlock the bottom bolts of the module with a screwdriver!
- Remove the module from the DIN rail without touching or damaging the bus connector contacts.

ATTENTION

Material damage due to disassembly or decoupling of the module during operation!

Dismounting or decoupling the module during communication with the basic device can cause damage to your devices!

- Disconnect your system from the power supply prior to dismantling or disconnecting the module! Secure it against being switched back on! Check to be sure it is de-energized! Ground and short circuit! Cover or block off adjacent live parts!

Proceed analogously when dismantling the 800-CON-RJ45 transfer module with output and input bus connector:

1. Disconnect the supply of power to the system! Secure it against being switched on! Check to be sure it is de-energized! Ground and short circuit! Cover or block off adjacent live parts!
2. Disconnect the wiring of the transfer module.
3. Remove or move the end brackets of your series of measurement devices and modules.
4. Disconnect the bus connectors (JanBus interface) of the transfer module from the basic device or the connected module by pulling them out.
5. Unlock the bottom bolts of the transfer module. **Recommendation:** Use a screwdriver (be careful!).
6. Remove the transfer module from the DIN rail without touching or damaging the bus connector contacts.

For a module exchange, please refer to the dismantling and reassembly of the transfer module as described above (see Sect. "4. Mounting" on p. 16).

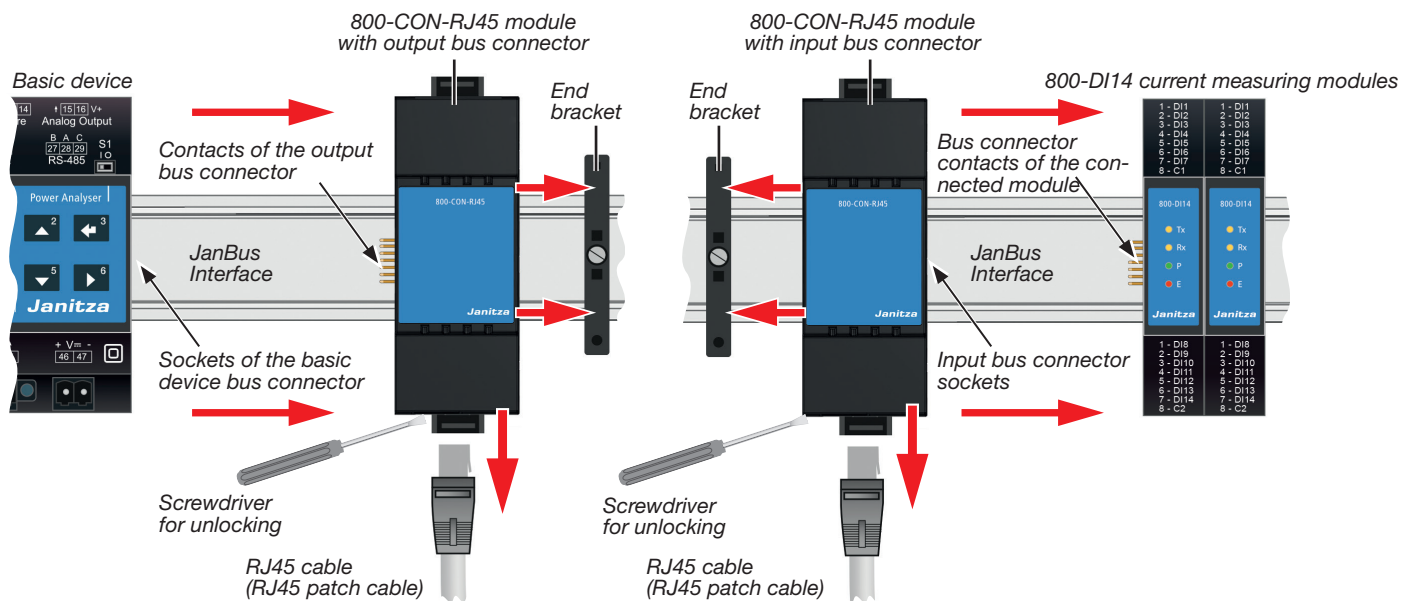

Fig. Dismounting the 800-CON-RJ45 transfer module with output bus connector

Fig. Dismounting the 800-CON-RJ45 transfer module with input bus connector

 INFORMATION

After dismantling or exchanging the 800-CON-RJ45 module, the GridVis software deactivates the connected modules of the measurement device and module topology as needed. Information on this and further procedures can be found in the online help for the GridVis software.

10. Service and maintenance

Your measurement device, module or component goes through various safety tests and is marked with a seal before delivery. If a measurement device, module or component is opened, the safety tests must be repeated. A warranty is only provided for unopened measurement devices, modules or components.

10.1 Repair

Repairs can only be carried out by the manufacturer.

10.2 Service

If questions arise that are not described in this user manual, please contact the manufacturer.

The particulars and information required to identify problems with the measurement device, module or component should be as complete as possible. Consequently, please have the following information ready to answer any questions:

- Device designation (see rating plate).
- Measured voltage and supply voltage.
- An exact error description.

If available:

- Serial number (see rating plate).
- Hardware version (see system display).
- Software release (see system display).

10.3 Device adjustment

Devices modules and components are adjusted by the manufacturer prior to outbound delivery. No readjustment is required when the environmental conditions are complied with.

10.4 Calibration interval

No calibration is required for the 800-CON-RJ45 transfer module. For the calibration of further components and modules of your meter and module topology, please refer to the respective usage information.

10.5 Firmware update

No firmware update is required for the 800-CON-RJ45 transfer module. For a firmware update of the further modules and components of your measurement device and module topology, please refer to the respective usage information.

INFORMATION

This user manual describes the 800-CON-RJ45 transfer module and provides information on operating the module via the basic device.

In addition to this user manual, observe the usage information for the respective measurement devices, modules and components of your measurement device and module topology.

Moreover, the **GridVis** Power Grid Monitoring Software has an "online help" feature.

10.6 Procedure in the event of a malfunction

ATTENTION

An error in the communication with the basic device leads to a device fault!

If communication from the basic device to the modules is lacking or faulty during operation, a warning signal will appear on the display of the basic device.

Prior to dismantling or disconnecting the modules of the basic device (the system)

- **Disconnect the supply of power! Secure it against being switched on! Check to be sure it is de-energized! Ground and short circuit! Cover or block off adjacent live parts!**
- **Prior to remounting, it may be necessary to restart the basic device.**
- **Also take note of the chapter "Procedure in the event of a malfunction" in the documentation of your basic device.**
- **If the measures indicated here are unsuccessful, please contact our support team (www.janitza.com).**
- **If there is discernible damage, send the device, module or component back to the manufacturer in compliance with proper transport conditions.**

10.7 Resetting the module to the standard factory settings

The 800-CON-RJ45 transfer module does not require a "reset to factory settings".

Janitza

Janitza electronics GmbH
Vor dem Polstück 6 | 35633 Lahnau
Germany

Tel. +49 6441 9642-0
info@janitza.com | www.janitza.com